



# TR-10 16 MESSAGES DIGITAL RECORDER.



The TR-10 module is a digital Recorder / Player for voice, music or sound with a non volatile storage memory having 8 minutes as maximum capacity.

It allows to share the total time in different combinations as concern time and number of messages, with a maximum of 16 messages of 30 sec. and a minimum of 1 message of 8 minutes.

It allows to play in normal or repetitive mode, to record through a microphone or RCA input, and it includes a power stage, volume control and indicator leds.

It can be installed in a DIN-RAIL Ref. C-7588

### TECHNICAL CHARACTERISTICS.

Voltage.....	12 V. D.C.
Min./Max. consumption.....	.40 / 500 mA.
Output power.....	.5 W. (RMS at 4 Ohms).
Output Impedance.....	.4 - 8 Ohms.
Inputs signal Rec and Play.....	.5 V.D.C. / 5 mA. (Activation at low level).
Maximum input signal RCA.....	.30 mV.
Input Impedance RCA.....	.56 KW.
Maximum recording time.....	.8 minutes.
Maximum number of messages.....	.16.
Typical memory's duration.....	100.000 cycles /100 years maintained message.
Sampling Frequency.....	.8 KHz.(not variable).
Automatic Gain Control, (AGP).....	Automatic.
Protection against inversion of polarity.....	Feed input.
Dimensions.....	107 x 110 x 30 mm

### POWER SUPPLY AND INSTALLATION.

**POWER SUPPLY.** The TR-10 circuit had to be supplied with a power supply correctly filtered. We recommend you to use a short circuitable power supply with a low ripple level. Do never use basic power supplied or rectifiers to avoid to damage the module's operating mode. For this reason, we suggest you to our Cebek Ref. FE-123 power supply, which has been developed to perfectly answer to the circuit needs.

Connect the positive and the negative of the power supply to the positive and negative terminal of the input module. See the general wiring map.

**Note:** Install a fuse and a switch has it is indicated on the schedule. Both are necessary for the module's protection as well as for your own safety, as it is required by the "CE" regulations. Consult the corresponding power supply's instruction manual. Then, Verify that the assembly is correct.

**INSTALLATION.** The module's installation has to be preferably done into an enclosure or a rack, correctly ventilated, avoiding any contact between the circuit and metal objects.

Do not install the device in humid places, under high temperatures, or in contact with liquids.

Do not supply the module before to finish its installation. Please carefully read this instruction manual.

**Rec and Play Inputs.** To activate these inputs you have to use non potential devices like push buttons, switches, etc... When both contacts of the Rec input are closed or the ground terminal with the message one on the Play input, internally the module place at low level the corresponding signal. For this reason, you don't have to inject signal through these inputs.

**RCA input.** The RCA input allows to inject an external audio signal to the circuit, to make easier the direct sound recording coming from other devices. Nevertheless, the signal level coming from these devices has to be inferior to the maximum level admissible by the circuit (36 mV. Vpp), otherwise the module will be damaged. For this reason, you only can connect to the RCA input the headphone output of devices with an output not referred to the ground (most of standard audio player). Respect the polarity of the RCA connector (Fig.1) and consult the Recording paragraph, where it is indicated the RCA selection mode as source to record.

Fig. 1. Polarity of the RCA connector audio input.

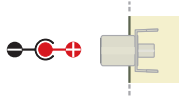

**Wiring.** For the wiring, you have to respect the polarity of different inputs, and the cable length has to be as short as possible (Power, RCA, Rec and Play inputs). For these inputs, except Power, you have to use shielded cable and to connect the braid to the screw indicated with the ground symbol (negative). Remember that the maximum length has to be inferior to 2m

For the power supply input, (Power), you have to use parallel cable with a maximum length of 2 m.

**Loudspeaker output.** The maximum power offered by the device is 5W. Anyway, we suggest you to use a 10W loudspeaker as minimum, with an impedance of 4 or 8 Ohms. For this output, you can use standard parallel cable.

### OPERATING MODE.

**INDICATORS.** There are four indicator leds on the circuit.

**Repeat Led.** (Yellow). It will light on to indicate the activation of the Repetitive Play function.

**Rec. Led.** (Red). It will light on only when the module's Record mode is selected.

**Play Led.** (Green). It will light on only when the module's Play mode is selected.

**Run Led.** (Green). From the beginning till the end of the recording register or during a message playing, the Run led will be intermittently light on.

**Dip SET FUNCTION.** The different module's functions like messages number, repetitive operating mode, etc... are configured through the Dip composed by 8 micro switches and incorporated on the circuit. It is indicated as SET. See Fig.2.

Fig. 2. Dip SET. Assigned functions for each switch.

To configure functions according switch position : On or Off.

	Switch	ON	OFF
Recording Protection	Switch 1	Allow to Record	Avoid to Record
Repeat Function	Switch 2	Activated	Deactivated
Mute Function	Switch 6	Sound on Loudspeaker	Silence on Loudspeaker

Switches Nº 3, 4 and 5 will establish the time and the number of message, as it is described hereafter. Switches 7 and 8 don't incorporate any function.

**TO CONFIGURE the NUMBER and TIME OF MESSAGES.** The module allows to operate with a single message with a maximum of 8 minutes, or different combination of numbers and the consecutive division of the assigned time to each one. According to the ON or OFF position for switches Nº 3, 4 and 5 you will obtain a different combination. See Fig. 3.

Fig. 3. Dip SET. To configure the number/time of messages.

Number of messages according to the combination between switches 3, 4 and 5.

	Switch 3	Switch 4	Switch 5
1 message of 8 min.	Off	Off	Off
2 messages of 4 min.	Off	Off	On
4 messages of 2 min.	Off	On	Off
8 messages of 1 min.	Off	On	On
12 messages of 40 sec.	On	Off	Off
16 messages of 30 sec.	On	Off	On
1 message of 4 min. + 4 messages of 1 min.	On	On	Off
4 messages of 1 min. + 4 messages of 30 sec.	On	On	On

### OPERATING MODE.

Recording and playing will be conditioned by this selection, because both have to be done in the same messages configuration that originally selected. Otherwise, the module doesn't play correctly.

Do not forget that the number of selected messages will be always assigned from the message input Nº1 and so on. For instance, if you have configured the module to operate with 8 messages, only inputs Nº1 and 8 will be operative, and the rest of inputs will be not operative.

### RECORDING.

Protection against involuntary recording. The module includes a protection against the involuntary recording. If you place the switch 1 in position OFF, the device denies the recording. At the opposite, if you place the switch 1 in ON position, the circuit will allow it.

### Recording through microphone.

To record through a microphone, you have to close JP1 and JP2 jumpers on the circuit and to not introduce signal through the RCA input (See Fig.4).

To record, it is necessary to get closer the microphone and to emit the sound with deep and power. The module includes an automatic gain control (AGC), allowing the stabilisation of the signal level caught by the microphone.

Fig. 3. To select the Audio Input source for Recording.

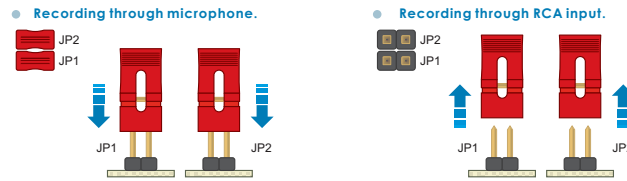

### Recording through RCA input.

To record through the RCA input, you have to open JP1 and JP2 jumpers (See Fig.4). Then when you start recording, the circuit will store in its memory the audio signal caught through this input.

### Recording process.

The recording function is selected closing the two screws of the REC input (the Red Led will light on).

To start the recording you have to momentary connect the ground terminal to the terminal of the message on which you want to record.

The recording will be automatically stopped when the maximum time of the message is exhausted or suddenly deactivating the connection of the two Rec terminals.

During the recording process, it is recommended to maintain activated the Mute function (switch 6 in OFF position), explicate later.

### PLAYING.

**Mute Function.** This function will operate independently of playing inputs. When the switch 6 is in OFF position, the mute function will maintain in silence the loudspeaker output. When the switch 6 is in ON position, the module will allow the audio output through the loudspeaker.

**Playing process.** The playing function will be activated when the two terminals of Rec input are open (Play Led light on).

The playing of each message is independently executed when the ground terminal is closed with the terminal of the message that you want to play. The playing is automatically stopped when you arrive at the end of the recorded message, independently of the maximum time accepted by the memory. In the repetitive function, once you arrive at the end of the recorded message, the circuit will automatically restart the playing.

The module doesn't allow to activate a message if it is already playing a message. You have to wait the end before to activate any other message.

**Repetitive playing.** The repetitive function allows to cyclically play a message till the selection terminal of this one are closed. To activate this function, you have to use the switch 2. When this one is in ON position, the module will allow the repetitive function. With the switch 2 in OFF position, at the end of the recorded message, the playing will be stopped (even if selection terminals of this message are still closed).

**Volume control.** The device allows to adjust the playing volume level through the potentiometer inserted on the circuit, and indicated as "Volume". We strongly recommend you to not place the potentiometer at the maximum to avoid to saturate the output, distorting the sound.

### GENERAL WIRING MAP.

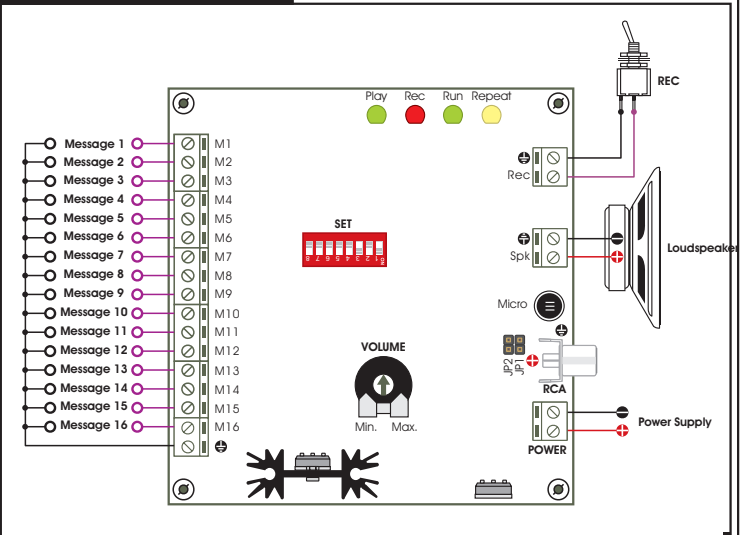

### WARRANTY AND TECHNICAL CONSULTATIONS.

All cebek modules have a total warranty of 3 years as concern components and labour man. All damage, error or mistake due to problems independent from the circuit, connection, installation or operating mode, as well as wrong handling are not included in this warranty. More over it will be necessary the purchase invoice of this module for any claim.

This manual (documentation) can be reviewed or modified without any previous communication, and it doesn't involve FADISEL S.L. The use of any of the FADISEL modules' mentioned in this manual provoke the acceptance of these commercial terms and correspondent warranty.

To contact our technical depart. Please contact: - Sat@cebek.com, or by fax (+34) 93.432.29.95 or by mail at the following address: FADISEL - c/Quetzal, 17-21 - 08014 Barcelona - SPAIN.



**CEBEK's** MORE! CEBEK offers a Wide and complete modules range which can be of your interest. Visit our web site: [www.cebek.com](http://www.cebek.com)