

USER MANUAL

FEBRUARY 2016

MM101 DIGITAL SENSOR TEMPERATURE BOARD

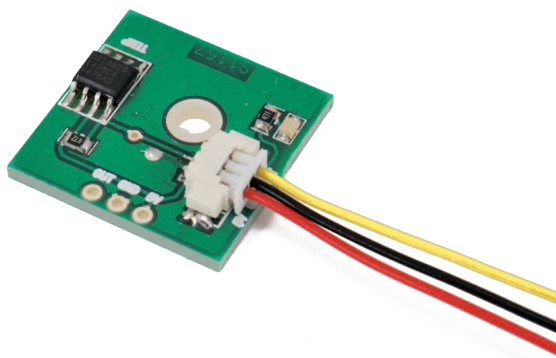

USING THE SENSOR

This temperature sensor provides a digital output signal to allow easy interfacing to a microcontroller or a microprocessor using the 1-Wire® communication protocol. Since communication with the sensor is digital, it can be placed at a distance from the controller circuit without worrying about disturbances and interference from the surrounding environment.

The thermal sensor board uses three connections: Vcc (5V power), GND and a bidirectional data line (DQ). The DS18B20's temperature measurements range between -55°C and +125°C and are expressed in 9 to 12 bit resolution (user definable) with ±0.5°C accuracy in the -10°C to 85°C range. Resolution is set through the configuration register.

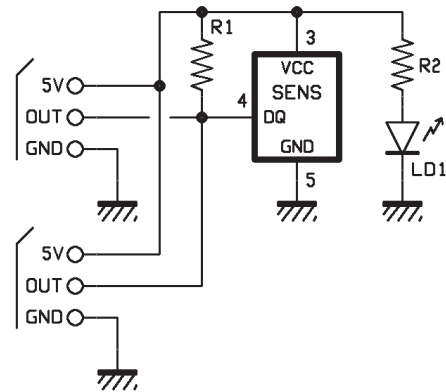
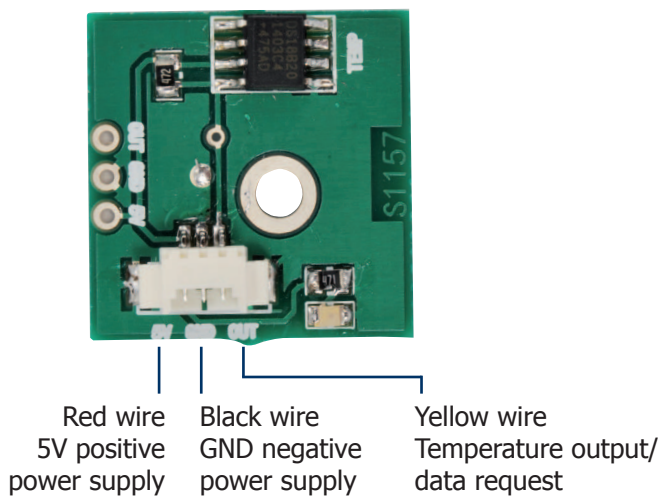

To begin temperature measurement and A/D conversion the “Convert T” (code: 44h) command is issued. The sensor transmits a 0 during the conversion and returns a 1 when the operation is complete. The resulting two bytes are available in the sensor’s scratchpad memory and correspond to the measured temperature, expressed in Celsius. The “Read ScratchPad” (code: BEh) command is used to access the measurement from memory. The 2-byte register (for an 11-bit sampling) is structured as shown in Fig. 1. The structure of the 2 bytes returned in 11-bit mode are as follows: the first 11 bits (including all of the least significant byte and the first three bits from the most significant byte) express the temperature value, the last five express the sign and are all 0’s if the temperature is positive (above zero) and all 1’s if the temperature is negative (below zero).

The DS18B20 is capable of expressing temperatures with decimal values. Looking at Fig. 1, you will see that the first four least significant bit values are less than 1. The first one 0.0625, the second one is 0.125, that the third one is 0.25 and that the fourth one is 0.5.

	bit 7	bit 6	bit 5	bit 4	bit 3	bit 2	bit 1	bit 0
LS Byte	2^3	2^2	2^1	2^0	2^{-1}	2^{-2}	2^{-3}	2^{-4}
	bit 15	bit 14	bit 13	bit 12	bit 11	bit 10	bit 9	bit 8
MS Byte	S	S	S	S	S	2^6	2^5	2^4

Fig. The structure of the two bits successively emitted by the MM101, each time it is queried: the LS byte is the one weighing less, while the MSB byte is the more significant one. This structure is referred to as an 11-bit representation, plus sign.

EXAMPLE

Here's an example of a measurement with a decimal value:

Suppose a measurement is taken for a positive value of 64.25°C. The two bytes returned will be 00000100 (MSB) and 00000100 (LSB). Referring to figure 1 again, you will see that the LSB returned a value of 0.25 and the MSB returned a value of +64 degrees.

For 12-bit resolution all the bits will contain data, for 11-bit resolution bit 0 is undefined, for 10-bit resolution bits 1 and 0 are undefined and for 9-bit resolution bits 2, 1 and 0 are undefined.

Considering the data as a whole (composed of the two bytes) the possible output range of the DS18B20 is between 1111101101110000(-55 °C) and 0000011111010000 (+125°C).

These values can then be converted to hexadecimal format: AB70h and 07D0h, continuing conversion to hexadecimal, we see that a temperature value of 10.125C corresponds to 00A2h, while a value of -20C would be written BCC0h.

For the complete list of specifications and commands for the DS18B20 temperature sensor, refer to the datasheet and applications notes from Maxim Integrated™. Available for download from www.maximintegrated.com.

The complete article concerning this project is published in: Elettronica In, issue n.191

velleman®

ORDERCODE: MM101

REVISION: HMM101



VellemanProjects



@Velleman_RnD

VELLEMAN nv - Legen Heirweg 33, Gavere (Belgium)
vellemanprojects.com