

START

1

Resistor - Weerstand - Résistance - Widerstand - Resistencia - Motstand - Vastus - Resistenze

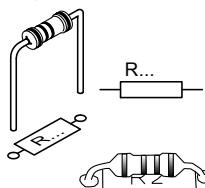

◇ R1 ... R4, R13 : 4K7

(Yellow, Purple, Red) - (Geel, Paars, Rood) - (Jaune, Violet, Rouge) - (Gelb, Violet, Rot) - (Gul, Lila, Röd) - (Keltainen, Purppura, Punainen) - (Amarillo, Morado, Rojo) - (Amarelo, Violeta, Encarnado) - (Giallo, Viola, Rosso)

◇ R5:47K

(Yellow, Purple, Orange) - (Geel, Paars, Oranje) - (Jaune, Violet, Orange) - (Gelb, Violet, Orange) - (Gul, Lila, Orange) - (Keltainen, Purppura, Oranssi) - (Amarillo, Morado, Naranjado) - (Amarelo, Violeta, Laranja) - (Giallo, Viola, Aranciato)

◇ R6 ... R12 : 100K

(Brown, Black, Yellow) - (Bruin, Zwart, Geel) - (Brun, Noir, Jaune) - (Braun, Schwarz, Gelb) - (Brun, Svart, Gul) - (Ruskea, Musta, Keltainen) - (Marrón, Negro, Amarillo) - (Castanho, Preto, Amarelo) - (Marrone, Nero, Giallo)

◇ R14 : 2K2

(Red, Red, Red) - (Rood, Rood, Rood) - (Rouge, Rouge, Rouge) - (Rot, Rot, Rot) - (Röd, Röd, Röd) - (Punainen, Punainen, Punainen) - (Rojo, Rojo, Rojo) - (Encarnado, Encarnado, Encarnado) - (Rosso, Rosso, Rosso)

◇ R15 : 470

(Yellow, Purple, Brown) - (Geel, Paars, Bruin) - (Jaune, Violet, Brun) - (Gelb, Violet, Braun) - (Gul, Lila, Brun) - (Keltainen, Purppura, Ruskea) - (Amarillo, Morado, Marrón) - (Amarelo, Violeta, Castanho) - (Giallo, Viola, Marrone)

10

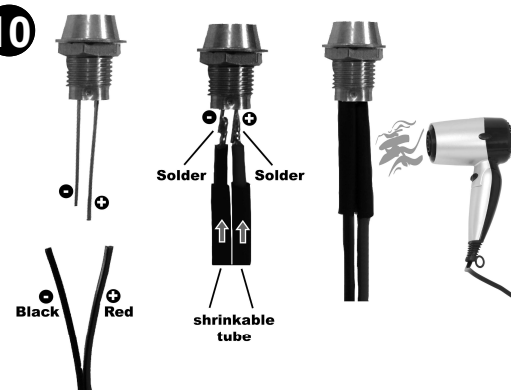

GB: (1) Hook-up the circuit to the vehicle electrical system * (2) Adjust RV1 until the LED flashes when the engine is not running * (3) Start the engine * The LED should turn off * If not, adjust RV1 slightly * Repeat procedure if necessary.

NL: (1) Sluit de schakeling aan op de boordspanning * (2) Regel bij uitgeschakelde motor RV1 zodanig dat de LED knippert * (3) Start de motor * Normaal dooft de LED, zoniet dient men RV1 een weinig bij te regelen * Herhaal indien nodig de procedure.

F: (1) Connectez le circuit sur le réseau de bord * (2) Réglez RV1 de sorte que la LED clignote quand le moteur est coupé * (3) Allumez le moteur * La LED devrait s'éteindre * Sinon, vous devez légèrement ajuster RV1 * Répétez cette procédure si nécessaire.

D: (1) Schließen Sie die Schaltung an das Autobordnetz an * (2) Regeln Sie das Potentiometer RV1 nach dem Ausschalten des Motors in solcher Weise, dass die LED blinkt * (3) Schalten Sie den Motor ein * Normalerweise erlischt die LED * Wenn dies nicht der Fall ist, müssen Sie das RV1 etwas mehr regeln * Wenn nötig, müssen Sie dieses Verfahren wiederholen.

S: (1) Koppla in kretsen till fordonets elsystem. * (2) Justera RV1 tills LED börjar blinka när motorn är avstängd. * (3) Starta motorn, LED skall stockna. * Om inte, justera försiktigt RV1. * Repetera proceduren för test eller omkallbrering.

11

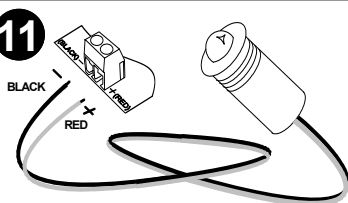

E: (1) Conecte el circuito a la red de tensión del coche * (2) Regule el potenciómetro RV1 después de haber parado el motor de tal manera que la LED enciende y apaga * (3) Arranque el motor * Se apaga normalmente la LED * Si no es el caso, regule el RV1 un poco más * Si hace falta, repita este procedimiento.

I: (1) Collegare il circuito all'impianto elettrico del veicolo. * (2) Regolare RV1 finché il LED lampeggia quando il motore è fermo. * (3) Avviare il motore. * Il LED deve spegnersi. * Altrimenti regolare leggermente RV1. * Ripetere la procedura se necessario.

SF: (1) Liitä piiri ajoneuvon sähköjärjestelmään. * (2) Säädä RV1 kunnes LED vilkkuu (kun moottori ei käy). * (3) Käynnistä moottori. * LEDin pitäisi sammua. * Jos ei säädä RV1 hieman. * Toista toimenpide tarvittaessa.

DK: (1) Tilslut kredsløbet til bilens elektriske system. * (2) Juster RV1, indtil lysdioden blinker når motoren ikke er i gang. * (3) Når motoren startes, skal lysdioden slukke. * Hvis dette ikke sker, justeres RV1 en smule. * Gentag justeringen, indtil den ønskede funktion opnås.

12

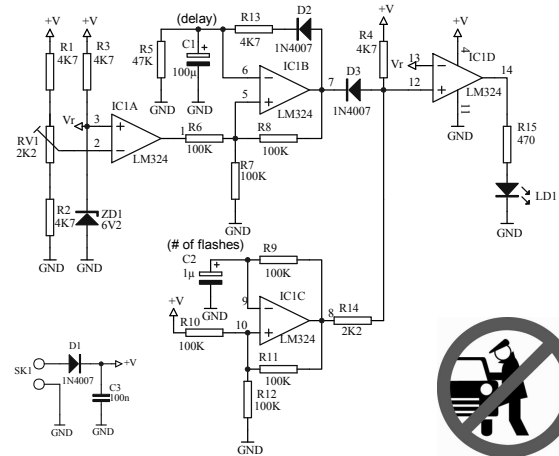
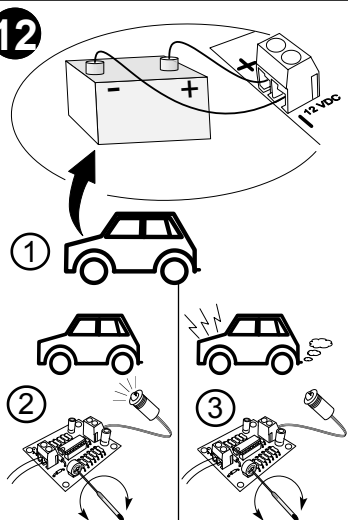

2 DIODE

Watch the polarity!
Attention à la polarité!

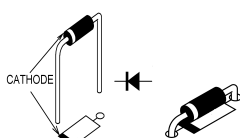

◇ D1 ... D3 : 1N4007

3 ZENER DIODE

Watch the polarity!
Attention à la polarité!

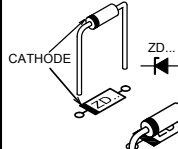

◇ ZD1 : 6V2

4 IC SOCKET

WATCH THE POSITION
OF THE NOTCH!
ATTENTION A LA POSITION DE
L'ENCOCHE!

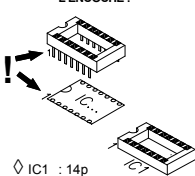

◇ IC1 : 14p

5 ELECTROLYTIC CAPACITOR

WATCH THE POLARITY!
ATT. À LA POLARITÉ!

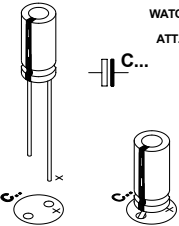

◇ C1 : 100µF
◇ C2 : 1µF

6 CAPACITOR

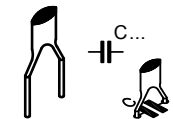

◇ C3 : 100nF (104)

7 RESISTOR TRIMMER

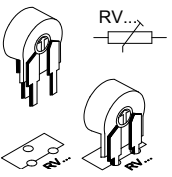

◇ RV1 : 2K2 (2K5)

8 TERMINAL BLOCK

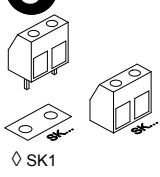

◇ SK1
◇ SK2

9 IC

WATCH THE POSITION
OF THE NOTCH!
ATTENTION A LA POSITION
DE L'ENCOCHE!

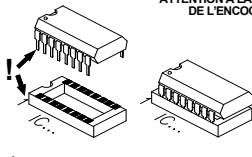

◇ IC1 : LM324 (LM224)