

QUASAR ELECTRONICS KIT No. 1053 ELECTRONIC METRONOME

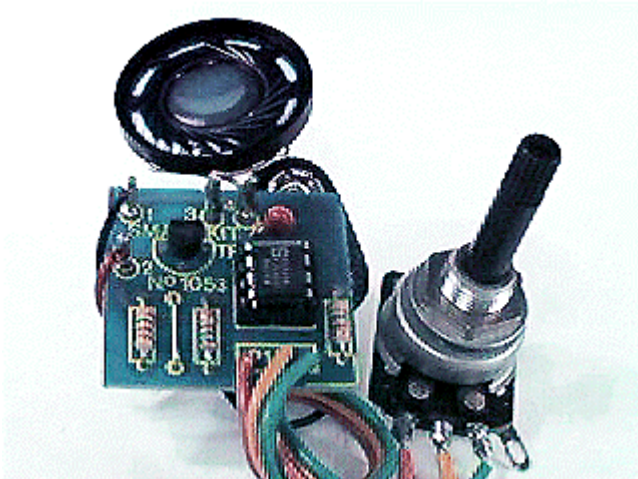

General Description

This is a very useful metronome for musicians or for any person who needs a simple means to keep a rhythm. It uses very few components and produces an audible click in the loudspeaker as often as its setting dictates.

Technical Specifications - Characteristics

Working voltage: 9 V DC
Current: 30 mA

How it Works

The circuit uses the well known timer IC NE555 as an oscillator. The frequency of the oscillator depends on the RC ratio $(P1+R3)/C1$. C1 is a tantalum bead for greater accuracy. Whenever a pulse appears at pin 3 of the IC the transistor is driven hard on and a click is heard from the speaker. (It is the equivalent of connecting a small battery across a loudspeaker.

Changing the setting of P1 will change the frequency of the oscillator to produce a click at a rate varying from less than once a second to more than one hundred per second. The circuit operates from 9 VDC and as it has a very low consumption it will work for a long time with a miniature 9 V battery.

Construction

First of all let us consider a few basics in building electronic circuits on a printed circuit board. The board is made of a thin insulating material clad with a thin layer of conductive

copper that is shaped in such a way as to form the necessary conductors between the various components of the circuit. The use of a properly designed printed circuit board is very desirable as it speeds construction up considerably and reduces the possibility of making errors. Quasar Electronics Kit boards also come pre-drilled and with the outline of the components and their identification printed on the component side to make construction easier. To protect the board during storage from oxidation and assure it gets to you in perfect condition the copper is tinned during manufacturing and covered with a special varnish that protects it from getting oxidised and also makes soldering easier. Soldering the components to the board is the only way to build your circuit and from the way you do it depends greatly your success or failure. This work is not very difficult and if you stick to a few rules you should have no problems. The soldering iron that you use must be light and its power should not exceed the 25 Watts. The tip should be fine and must be kept clean at all times. For this purpose come very handy specially made sponges that are kept wet and from time to time you can wipe the hot tip on them to remove all the residues that tend to accumulate on it. DO NOT file or sandpaper a dirty or worn out tip. If the tip cannot be cleaned, replace it. There are many different types of solder in the market and you should choose a good quality one that contains the necessary flux in its core, to assure a perfect joint every time. DO NOT use soldering flux apart from that which is already included in your solder. Too much flux can cause many problems and is one of the main causes of circuit malfunction. If nevertheless you have to use extra flux, as it is the case when you have to tin copper wires, clean it very thoroughly after you finish your work. In order to solder a component correctly you should do the following:

- Clean the component leads with a small piece of emery paper.
- Bend them at the correct distance from the component's body and insert the component in its place on the board.
- You may find sometimes a component with heavier gauge leads than usual, that are too thick to enter in the holes of the p.c. board. In this case use a mini drill to enlarge the holes slightly. Do not make the holes too large as this is going to make soldering difficult afterwards.
- Take the hot iron and place its tip on the component lead while holding the end of the solder wire at the point where the lead emerges from the board. The iron tip must touch the lead slightly above the p.c. board.
- When the solder starts to melt and flow wait till it covers evenly the area around the hole and the flux boils and gets out from underneath the solder. The whole operation should not take more than 5 seconds. Remove the iron and allow the solder to cool naturally without blowing on it or moving the component. If everything was done properly the surface of the joint must have a bright metallic finish and its edges should be smoothly ended on the component lead and the board track. If the solder looks dull, cracked, or has the shape of a blob then you have made a dry joint and you should remove the solder (with a pump, or a solder wick) and redo it.
- Take care not to overheat the tracks as it is very easy to lift them from the board and break them.
- When you are soldering a sensitive component it is good practice to hold the lead from the component side of the board with a pair of long-nose pliers to divert any heat that could possibly damage the component.
- Make sure that you do not use more solder than it is necessary as you are running the risk of short-circuiting adjacent tracks on the board, especially if they are very close together.
- When you finish your work cut off the excess of the component leads and clean the board thoroughly with a suitable solvent to remove all flux residues that still remain on it.

The metronome only has 8 components with the loudspeaker. The use of the p.c. board

makes its construction even simpler. Solder first of all the pins for the external connections on the board and then insert the IC socket in its place making sure it has the correct orientation and solder all its pins carefully. Solder then the resistors, the potentiometer and the tantalum capacitor taking care to insert it the right way round as it is polarised. Finally solder the transistor carefully as overheating can damage it and insert the IC in its socket aligning the notch on its body with the notch on the socket. The metronome is ready and after a careful visual inspection you can use it.

Connect the speaker across points 3 and 4 of the p.c. board and a miniature battery at points 1 (-) and 2 (-) using the battery clip provided. The speaker should start clicking and the frequency of the clicks should change if you turn the potentiometer.

Adjustments

This kit does not need any adjustments, if you follow the building instructions.

Warning

Quasar Electronics kits are sold as stand alone training kits.

If they are used as part of a larger assembly and any damage is caused, our company bears no responsibility.

While using electrical parts, handle power supply and equipment with great care, following safety standards as described by international specs and regulations.

If it does not work

- Check your work for possible dry joints, bridges across adjacent tracks or soldering flux residues that usually cause problems.
- Check again all the external connections to and from the circuit to see if there is a mistake there.
- See that there are no components missing or inserted in the wrong places.
- Make sure that all the polarised components have been soldered the right way round.
- Make sure that the supply has the correct voltage and is connected the right way round to your circuit.
- Check your project for faulty or damaged components.

If your project still fails to work, please contact us for information about our Get-You-Going service.

Electronic Diagram

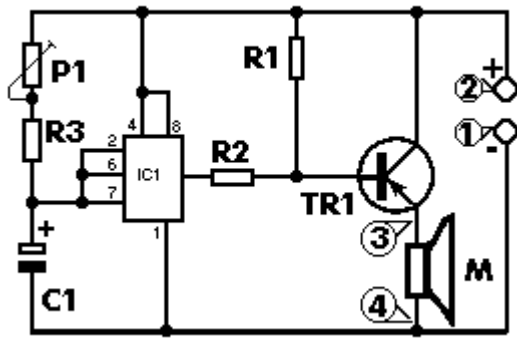

Parts List

All components including printed circuit board, assembly instructions including schematics and detailed parts list are supplied when you purchase the kit.

Ordering

For pricing info and online ordering please visit:

<http://www.quasarelectronics.com/1053.htm>

For further info please contact us by e-mail:

[mailto: sales@QuasarElectronics.com](mailto:sales@QuasarElectronics.com)

COPYRIGHT © 2003 Quasar Electronics Limited. All rights reserved. Reproduction of this document in whole or in part in any form or medium without express written permission of Quasar Electronics Limited is prohibited.

E&OE