

Quasar Project # 3155 - Stereo Tone Control Unit

This is a stereo tone control unit which will make a useful addition to many of our power amplifier kits. It provides +/-12 dB of bass and treble boost/cut, and channel balance control.

Specification

D.C. Input :	6V – 15V DC.
Current Drain :	~ 10 mA
Maximum output :	> 3 V RMS (12V DC supply)
Maximum input :	> 3 V RMS
Gain (loss) :	-2 dB.
Input Z	~ 50 k ohm
Frequency resp. :	< 20 Hz to > 50 kHz – 3 dB
THD at 1kHz :	< 0.1 % at 1V output
S/N ratio :	> 85 dB re. 1V RMS
Bass boost/cut	~ 12 dB at 50 Hz
Treble boost/cut	~ 12 dB at 15 kHz

How it works

C1 couples the AC signal set by the volume and balance potentiometers to the base of Q1 via R2. Q1 acts as a class A, emitter follower, buffer stage. R1 and R3 set the DC voltage at the base to allow maximum signal swing. R2 determines the DC bias current and R4 provides the load impedance.

The AC output is coupled by C2 to the input of IC1 via a variable filter network which is also part of the feedback loop. With the bass and treble pots at their centre position, the impedance of the feedback circuit is balanced and will give a fixed gain at all frequencies within the pass band. When the pots are moved, the feedback ratio will increase or decrease at a frequency dependent rate governed by the capacitors C3 to C6 thereby providing the desired response curves.

R8 and R9 provide a DC bias on the op-amp input to allow it to operate from a single DC supply. C7 prevents the AC signal from varying this DC voltage level. C8 and R10 couple the AC signal to the power amplifier whilst blocking the DC voltage present at the

op-amp output. C9 and R11 provide power supply decoupling or filtering. If you are using a battery supply, you can replace R11 with a wire link to reduce battery consumption, although the difference is negligible.

Construction

Install the smaller components, starting with the resistors and the IC socket, with the notch as shown on the overlay. The IC will also have a notch or a dot at one end. Do not fit the IC until after you have soldered the socket into place though. Install the transistors, capacitors and PCB pins, leaving the pots until last. The volume pot is the log pot (A taper). Be careful when installing the transistors, they must go in the correct way as shown on the PCB overlay. The electrolytic capacitors are also polarised and the leads marked. The longer lead is positive, and should be inserted in the hole marked with the + sign.

Use only shielded cable for input and output connections, and make sure the power supply leads are as short as possible.

Testing

The power supply is critical to the noise performance of the pre-amp. A well regulated supply or plug pack should be used to reduce mains hum. However a regulator will not be necessary with a car or other battery supply. Make sure you test the voltage and polarity first in all cases before connecting to the board.

Make sure the volume control is turned down, and that the other pots are centred. Then connect a music source and power amp, and increase the volume slowly. You should hear the music. Check the operation of the Bass, Treble and Balance controls, being careful not to use full boost at high volume.

If there is no output, recheck all wiring, all component positions and polarity of transistors, caps, and orientation of the IC. Check for bad solder joints, and solder bridges between tracks, especially the IC pins.

Quasar Project # 3155 - Stereo Tone Control Unit

The complete data sheet for the MC4558 IC
can be obtained from our web site at :

<http://www.quasarelectronics.com/ds/mc4558.pdf>

Parts List

Resistors :

R1, R9, R13.....	56k (green,blue,orange)	3
R2, R10, R14, R20.....	1k (brown,black,red)	4
R3, R8, R15.....	47k (yellow,violet,orange) ...	3
R4, R16	2k2 (red,red,red)	2
R5,R6,R7,R17,R18,R19.....	10k (brown,black,orange)	6
R11	120R (brown,red,brown)	1
R12, R21	3k3 (orange,orange,red)	2

Capacitors :

C1,C2,C8,C10,C11,C16.....	10 uF/25Vcap	6
C3, C4, C12, C13	33 nF mono (333)	4
C5, C6, C14, C15	3n3F mono (332)	4
C7.....	33 uF/25V ecap	1
C9.....	100 uF/25V ecap	1

Misc. :

IC1.....	MC 4558	1
Q1, Q2.....	BC547	2
VR1	100k dual gang log pot. (A).....	1
VR2.....	100k single gang linear pot. (B)	1
VR3, VR4.....	50k dual gang linear pot. (B).....	2
3155 Printed Circuit Board		1
8 pin DIL IC socket		1
PCB pins		7

Quasar Project # 3155 - Stereo Tone Control Unit

Circuit Diagram

One channel shown only

Left Channel components in brackets

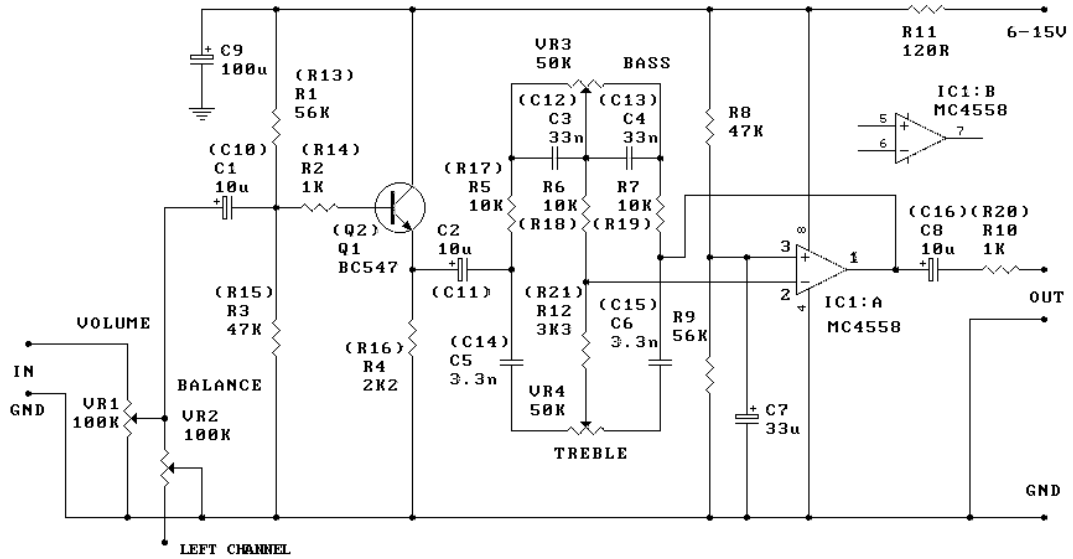

Quasar Project # 3155 - Stereo Tone Control Unit

THD at 1 kHz, 1V RMS output.

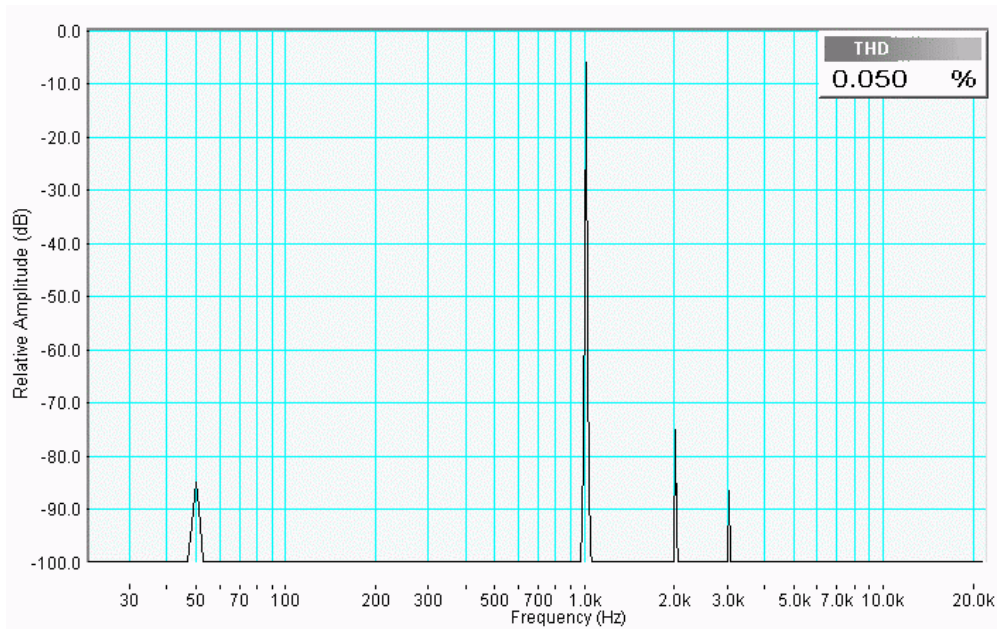

Effect of Tone Controls
Maximum Boost / Cut

